

# **DYMO<sup>®</sup>**

**LetraTag<sup>®</sup> 200B**

## User Guide



## Copyright

© 2022 Sanford, L.P. All rights reserved.

No part of this document or the software may be reproduced or transmitted in any form or by any means or translated into another language without the prior written consent of Sanford, L.P.

## Trademarks

DYMO and LetraTag are registered marks in the US and other countries. All other trademarks are the property of their respective holders.

Hereby, [NWL Belgium Services BV] declares that the radio equipment type [LetraTag 200B] is in compliance with EU Directive 2014/53/EU and UK Radio Equipment Regulations SI 2017 No. 1206. The full text of the EU and UK declarations of conformity are available at the following Internet address: [http://download.dymo.com\dymo\user-guides\LetraTag\LT200B\Declarations\LT200B\\_CE\\_UK\\_Declaration\\_Conformity.en.pdf](http://download.dymo.com\dymo\user-guides\LetraTag\LT200B\Declarations\LT200B_CE_UK_Declaration_Conformity.en.pdf)

## FCC Statement

**Caution:** The user is cautioned that changes or modifications not expressly approved by the party responsible for compliance could void the user's authority to operate the equipment.

**Note:** This equipment has been tested and found to comply with the limits for a Class B digital device, pursuant to part 15 of the FCC Rules. These limits are designed to provide reasonable protection against harmful interference in a residential installation. This equipment generates, uses and can radiate radio frequency energy and, if not installed and used in accordance with the instructions, may cause harmful interference to radio communications. However, there is no guarantee that interference will not occur in a particular installation. If this equipment does cause harmful interference to radio or television reception, which can be determined by turning the equipment off and on, the user is encouraged to try to correct the interference by one or more of the following measures:

- Reorient or relocate the receiving antenna.
- Increase the separation between the equipment and receiver.
- Connect the equipment into an outlet on a circuit different from that to which the receiver is connected.
- Consult the dealer or an experienced radio/TV technician for help.

This device complies with part 15 of the FCC Rules. Operation is subject to the following two conditions: (1) This device may not cause harmful interference, and (2) this device must accept any interference received, including interference that may cause undesired operation.

## IC Statement

This device contains licence-exempt transmitter(s)/receiver(s) that comply with Innovation, Science and Economic Development Canada's licence-exempt RSS(s). Operation is subject to the following two conditions:

(1) This device may not cause interference.

(2) This device must accept any interference, including interference that may cause undesired operation of the device.

This equipment complies with Industry Canada radiation exposure limits set forth for an uncontrolled environment.

Le présent appareil est conforme aux CNR d'Industrie Canada applicables aux appareils radio exempts de licence. L'exploitation est autorisée aux deux conditions suivantes : (1) l'appareil ne doit pas produire de brouillage, et (2) l'utilisateur de l'appareil doit accepter tout brouillage radioélectrique subi, même si le brouillage est susceptible d'en compromettre le fonctionnement.

Cet équipement est conforme à l'exposition aux rayonnements Industry Canada limites établies pour un environnement non contrôlé.

# Contents

---

- 1 About Your New Label Maker**
  - 1 Registering Your Label Maker
- 2 Getting to Know the Label Maker**
- 3 Getting Started**
  - 3 Inserting the Batteries
  - 3 Inserting the Label Cassette
  - 3 Power
- 4 Using Your Label Maker**
- 4 Caring for the Label Maker**
- 5 Troubleshooting**
- 6 General Safety Precautions**
- 6 Environmental Information**
- 6 Electrical Ratings**

## About Your New Label Maker

---

With the DYMO® LetraTag® 200B electronic label maker, you can create a wide variety of high-quality, self-adhesive labels. You can choose to print your labels in several different font sizes and styles. The label maker uses DYMO LT label cassettes. Labels are available in a wide range of colors and materials.

Visit [www.dymo.com](http://www.dymo.com) for information on obtaining labels for your label maker.

## Registering Your Label Maker

---

Visit [www.dymo.com/register](http://www.dymo.com/register) to register your label maker online. During the registration process, you will need the serial number, which is located on the bottom of the label maker.

Register your label maker to receive these benefits:

- Email notification of free software upgrades
- Special offers and new product announcements

## Getting to Know the Label Maker

---

Become familiar with the features shown in the following figure.

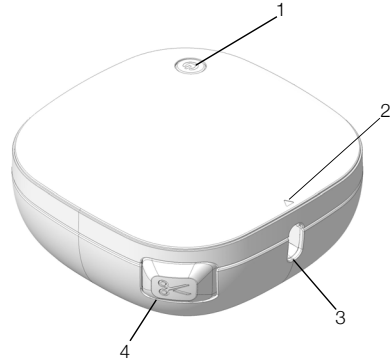

- |                             |                          |
|-----------------------------|--------------------------|
| <b>1</b> Power              | <b>3</b> Label exit slot |
| <b>2</b> Lift to open cover | <b>4</b> Cutter button   |

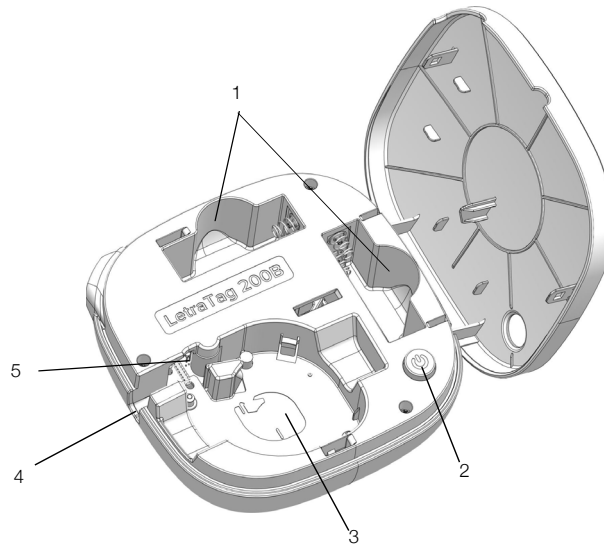

- |                               |                            |                       |
|-------------------------------|----------------------------|-----------------------|
| <b>1</b> Battery compartments | <b>3</b> Label compartment | <b>5</b> Cutter blade |
| <b>2</b> Power button         | <b>4</b> Label exit slot   |                       |

## Getting Started

---

Follow the instructions in this section to get started with your label maker.

### Inserting the Batteries

---

The label maker uses 4 high-capacity AA alkaline batteries.

#### To insert the batteries

- 1 Lift to open the cover.
- 2 Insert the batteries following the polarity markings (+ and -).
- 3 Close the cover.

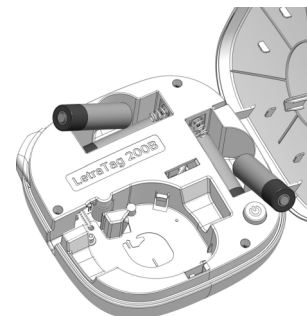

#### Safety Precautions

- Do not mix old and new batteries.
- Do not mix alkaline, standard (carbon-zinc), or rechargeable (ni-cad, ni-mh, etc.) batteries.
- Remove the batteries if the printer will not be used for a long period of time.

### Inserting the Label Cassette

---

Your label maker uses DYMO LT label cassettes. Visit [www.dymo.com](http://www.dymo.com) for information about purchasing additional label cassettes.

#### To insert the label cassette

- 1 Lift to open the cover.
- 2 Insert the cassette with the label positioned as shown.
- 3 Press firmly until cassette clicks into place.
- 4 Close the cover and press  to turn on the power.

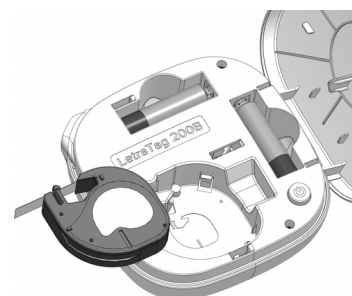

### Power

---

The  light will alternate from light to dark when the power is on. The power will automatically turn off after a few minutes of inactivity.

Remove the batteries if the printer will not be used for a long period of time.

## Using Your Label Maker

You print labels from a mobile device using the **DYMO LetraTag Connect** app available on the Apple® App store or the Google Play™ store.



### To print labels

- 1 From your mobile device's app store, search for **DYMO LetraTag Connect** to install the **DYMO LetraTag Connect** app.
- 2 Open the **DYMO LetraTag Connect** app and select a layout to create and print a label.

**NOTE:** Make sure the Bluetooth setting on your mobile device is turned on and the printer is within range of your device.

Refer to the **Troubleshooting** section if you have problems printing.

## Caring for the Label Maker

Your label maker is designed to give you long and trouble-free service, while requiring very little maintenance. Clean your label maker from time to time to keep it working properly. Clean the cutter blade each time you replace the label cassette.

 The cutter blade is extremely sharp. Use caution when cleaning.

### To clean the cutter blade

- 1 Lift to open the label maker cover.
- 2 Remove the label cassette.
- 3 Dampen a cotton ball with alcohol.
- 4 Place the tip of a ball-point pen or pencil on the black post as shown, and press the post down.
- 5 While holding down the post, press and hold the cutter button to expose the cutter blade.
- 6 Release the post and clean both sides of the blade with the cotton ball.
- 7 Release the cutter button.
- 8 After cleaning the blade, press and release the cutter button to return the cutter blade to the home position.

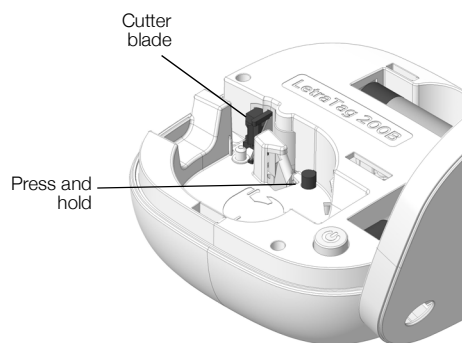

 You can also follow this procedure if the cutter blade becomes lodged in the forward position and will not move.

## Troubleshooting

---

Review the following sections if you encounter a problem with your label maker.

<b>Problem/Error Message</b>	<b>Solution</b>
Label maker does not turn on	<ul style="list-style-type: none"><li>■ Ensure the batteries are inserted properly. See <b>Inserting the Batteries</b>.</li><li>■ Replace discharged batteries.</li></ul>
Label doesn't print	<ul style="list-style-type: none"><li>■ Make sure the Bluetooth setting on your device is turned on.</li><li>■ Make sure the label maker is within range and power is turned on.</li><li>■ Replace discharged batteries.</li></ul>
Label maker error	<ul style="list-style-type: none"><li>■ Ensure the label cassette is inserted properly and not jammed or empty.</li><li>■ Ensure the batteries are inserted properly.</li></ul> See <b>Getting Started</b> .
Poor print quality	<ul style="list-style-type: none"><li>■ Ensure the label cassette is inserted properly. See <b>Inserting the Label Cassette</b>.</li><li>■ Replace the label cassette.</li><li>■ Replace the batteries.</li><li>■ Clean the print head. Contact DYMO Customer Support for instructions on how to clean the print head at <a href="http://support.dymo.com">support.dymo.com</a>.</li></ul>
Tape jam	Motor is stalled due to tape jam. <ul style="list-style-type: none"><li>■ Remove jammed label and replace label cassette.</li><li>■ Clean the cutter blade. See <b>Caring for the Label Maker</b>.</li></ul>
Poor cutter performance	Clean the cutter blade. See <b>Caring for the Label Maker</b> .

If you need further assistance, visit the DYMO Web site at [www.dymo.com](http://www.dymo.com).



## General Safety Precautions

---

Follow the guidelines in this section to use this product safely.

### Label Maker

- Do not insert objects into or block the label exit slot.
- Do not touch the cutter blade. Personal injury could result.
- Do not allow any liquids to come into contact with the label maker.
- Do not disassemble the label maker. For inspection, adjustment, or repair, contact DYMO Customer Support (<http://support.dymo.com>).

### DYMO Label Cassettes

- Use only DYMO-branded LT label cassettes in this label maker.
- Do not use any unauthorized accessories or supplies.
- Clean the surface before applying the adhesive label or the label may not adhere correctly and could peel off easily.
- Do not expose the labels to extreme heat or sunlight.

## Environmental Information

---

The equipment that you have bought requires the extraction and use of natural resources for its production. It may contain substances that are hazardous to health and the environment.

In order to avoid the dissemination of those substances in our environment, and to diminish the pressure on natural resources, we encourage you to use the appropriate take-back systems. These systems will reuse or recycle most of the materials of your end-of-life equipment in an environmentally sound way.

The crossed-bin symbol marked on your device indicates you should use these systems.



If you need more information on the collection, reuse, and recycling of this product, please contact your local or regional waste administration.

You can also contact DYMO for more information on the environmental performance of our products.

## Electrical Ratings

---

Power	6V DC The product is powered by 4 alkaline batteries, AA 1.5 V DC each (not included).
Frequency range	2400 - 2483.5 MHz
RF output power	<10 dBm

---